

EzLift

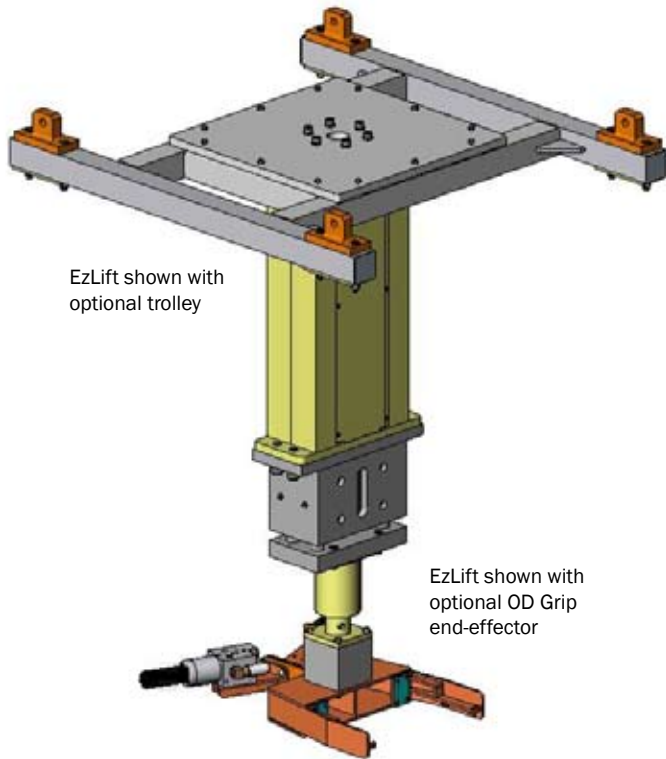

EzLift shown with optional trolley

EzLift shown with optional OD Grip end-effector

The Conco EzLift (EZ) is a cost effective in-line lifting device. The EzLift has up to 600 pounds of lift capacity and excels in assembly line handling and reach-in applications when combined with an overhead XY rail system or Conco Articulated Jib Arm.

Standard Features

- End of travel cushions for smooth operation
- Replaceable air cylinder
- Heavy duty construction for long life
- Pistol Grip metering valve control for vertical lift
- Tool Mount Plate for easy attachment of end-effectors
- Provides moment loading capabilities
- Does not require air lubricator

Available Options

- Optional Stroke adjustment for precise, repetitive operation
- Mounting Options: single arm jib crane, articulated jib crane or overhead bridge crane
- Up to 360° continuous end-effector rotation
- Multiple end-effectors available for various applications

Model	Capacity* (lbs/ kg)	Cylinder Bore (in/ mm)	Max Moment (in-lbs/ N-m)
EZ64-AG	78/35	2.5/63.5	3000/339
EZ64-BG	180/82	2.5/63.5	3000/339
EZ54-AG	300/136	3.0/76.2	5000/565
EZ54-BG	600/272	3.0/76.2	5000/565

*Requires 90 psi clean, dry air to operate at rated capacity
Stroke available in 12", 24", 36", 48" and 60"

